

# The computer process

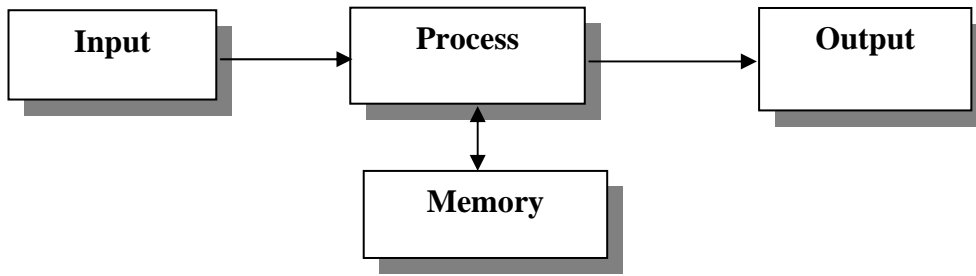

**CPU (Central Processing Unit)** - the 'brain' of the computer.

1. **The Control Unit** – which controls all operations inside the computer and controls the step by step running of programs .
2. **The ALU (Arithmetic and Logic Unit)** - which performs the calculations and logical operations on the data.
3. **Immediate Access Store or main memory** holds the programs currently or awaiting execution

## Types of computer

*Mainframes (including single processing and parallel processing computers), micro computers, embedded computers, laptops and palmtops;*

## Computer memory

Memory consists of a large number of store locations in which data can be store  
 Each store location is identified by an address. The storage capacity of memory is the measured amount of data they can store.

A standard floppy can hold 1.44 Mb

How many bytes is this?

<b>Bit</b>	Binary digit 0 1
<b>Byte</b>	8 bits
<b>Kilobyte</b>	1024 bytes in a kilobyte Kilobyte is $2^{10} = 1024$ bytes (thousand bytes)
<b>Megabyte</b>	Megabyte is $=2^{20} = 1048576$ bytes = 1024 K (million bytes)
<b>Gigabyte</b>	Gigabyte is $=2^{30} = 1024$ Mb (thousand million bytes)
<b>Word</b>	Largest number of bits a processor can handle at one time e.g. a 64 bit processor can handle 64 bits

## Memory inside the CPU

*(E.g. When you write a letter using a word processor then both the **word processing program** and the **letter** are stored in memory).*

**RAM (Random Access Memory)** is the type of memory used for **temporarily** storing programs and data. E.g your word processed letter before you save it. It is wiped clean when the power is switched off

**ROM Read Only memory** is a **permanent** non volatile memory which stores programs which cannot be overwritten they can only be read and is not lost when the power is switched off. e.g. system programs, Gui's

## Backing Storage

### Secondary (Backing) Storage

Speed is less important than large **storage capability**.

The most frequently used backing storage media are...

- **magnetic tape**
- **magnetic disk**
- **optical drives** (CD-ROM ; DVD)

<b>Magnetic media</b>	
<b>Magnetic Tape</b>	Commonly used for <b>backup</b> and <b>archiving</b>
<b>Magnetic Hard Disk</b>	Fast storage and access to data. Not portable Stores more data than a floppy and is more robust. 50Gb..
<b>Floppy disk</b>	1.44 mg Portable. Easily damaged
<b>ZIP</b>	Portable Special ZIP drive needed. Up to 250 Mb on one disc.
<b>Disk cache</b>	<i>(temporary, fast access e.g. storing web pages</i>

<b>Optical Disks</b>	
<b>CD-ROM/ DVD/ CDRW</b>	Laser technology is used to read data. Stores more data portable. expensive.

Large data files can be **compressed** for storage to save disk space  
e.g.If data files are too large to fit on a floppy they can be compressed (Zipped) to save disk space.  
Compressed files need to be **decompressed** therefore the need for a decompression program to be present when viewing files.

### Input/Output peripheral equipment.

A **peripheral** is a device which can be connected to a computer and controlled by it.

<b>Keyboard</b>	Allows <b>characters</b> to be input. Used on all computers. Particularly useful in word processing and command line OS (eg DOS)
<b>Mouse</b>	Used on PCs. Directs a screen pointer. Used in a <b>GUI</b> (WIMP) environment.
<b>Joystick</b>	Used on PCs mainly for games-playing.
<b>Touch screen</b>	User touches the screen to select menu items etc..Often used in public places eg libraries, museums where mouses or keyboards may be stolen.
<b>Light pen</b>	User 'writes' on the screen with the pen. Used for some <b>graphics (CAD)</b> or <b>art</b> packages.
<b>Graphics tablet</b>	Used for <b>graphics</b> packages to give a more natural 'feel'. User draws on tablet and results appear on the screen. Eg - could be used for tracing maps.
<b>Bar code reader</b>	Numerical data is coded as a sequence of lines. The reader can be passed over these lines and using a small laser the data can be read and input to the computer. Either built-in scanner or hand-held 'wand'. Used in shops, supermarkets (POS systems) libraries, and for reading ID cards.
<b>OCR reader</b> <b>OCR</b> <b>Handwriting recognition</b>	Optical Character Recognition. Scans and inputs characters from a printed sheet. The computer often converts handwriting into typed text. Inputs <b>text</b> into WP or DTP.(saves a lot of typing!). Also used for reading turnaround documents eg gas meter reading forms.
<b>Scanner</b>	Scans and inputs <b>images</b> from a printed sheet. Hand-held or flat-bed.
<b>Digital camera</b> <b>Web cam</b>	<b>Photos</b> can be downloaded into a computer and stored. Allows video conferencing across the Internet
<b>Mark-sense reader (OMR)</b>	Scans and inputs data represented by marks on a sheet. Eg school registers, multiple-choice exam papers, census forms, lottery tickets.
<b>MICR reader</b>	<b>Magnetic Ink Character Recognition.</b> Reads data electronically off bank cheques printed in magnetic ink using a special font. Very fast, and reliable. Prevents fraud and can read spoilt and crumpled cheques.
<b>Speech input</b>	Using microphones. Commands may be 'spoken' to the computer. Special software can convert speech into text data. Eg dictating a letter into a WP. Problems -different languages/ accents.
<b>Sound input</b>	Using microphone / tape / CD. Eg used for recording sounds for special effects in theatres, film studios etc.
<b>MIDI input</b>	<b>Musical Instrument Digital Interface.</b> Recording the sound patterns of musical notes using different instruments.
<b>Virtual Reality input</b>	Hardware devices eg digital glove are worn by the user, whose movements are sensed and used as input. A VR helmet may be used to project images for the user to 'interact' with.
<b>Sensor input</b>	Digital readings of eg light, sound, heat, movement, heart beat are measured and sent as analogue signals to be used as input for a control system.
<b>Magnetic strip</b>	A card with data recorded onto a magnetic strip are 'swiped' through a card reader, and data is read off it.
<b>Smart Card</b>	Cards with <b>chips</b> embedded into them are swiped through a special card reader.

<b>Braille keyboard</b>	Blind or partially blind can 'feel' the keys.
-------------------------	---

## Output Devices

<b>Monitor</b>	Screen displays are composed of a large number of pixels which display 'dots' in different colours. High-powered graphics can be used if a <b>graphics card</b> is fitted into a PC. Some have TFT screens (Thin film transistor) LCD Liquid crystal display and thin plasma screens
<b>Printer</b>	Used to create 'hard copy'. <b>Laser</b> printer (top) - good quality print; quiet. <b>Inkjet</b> printer (bottom) - cheaper; slow; can use colour.
<b>Graph Plotter</b>	Used to produce high quality graphics for <b>CAD</b> applications. eg building plans; microchip designs etc Flatbed plotter (top) or drum plotter (bottom)
<b>COM Computer Output on Microfilm/Microfiche</b>	Output documents greatly reduced in size onto film. <b>Microfilm</b> on a reel; <b>microfiche</b> on a flat sheet. Needs a special reader (pictured) to read them. Cuts down storage space for eg newspapers in a library..
<b>Sound output</b>	...using <b>speakers</b> . Useful for music; voices and sound effects for games; spoken warnings in cars; telephone banking. Also used on MIDI keyboards.
<b>Control signals</b>	Computers in <b>control systems</b> will send out control signals to activate devices. <i>actuators</i>
<b>CAD/Cam lathes</b>	Embroidery machines or lathes in DT.

## Input and output :Analogue and Digital

### Modem or an Analogue-digital converter.

**Digital** data can only have **distinct** values.

Eg a computer monitoring a light switch - it can only be 'on' or 'off'

**Analogue** data can vary **continuously** within a range of values.

if an analogue signal is sent to a computer, it would have to be converted to a digital signal first. Digital signals from the computer would have to be converted to analogue to control devices e.g motors.

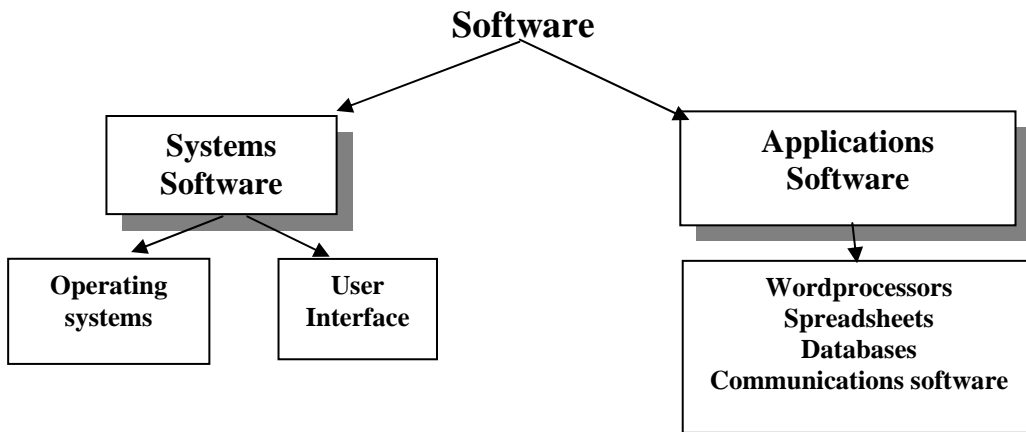

### Operating systems

“An operating system is a program or set of programs which control the hardware and allow users programs to run”

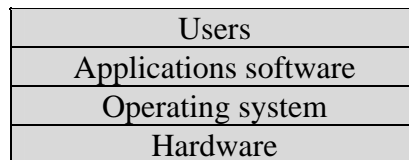

Operating systems should be

- Reliable**
- Efficient**
- Small**
- Maintainable**

### Functions of an operating system

- supervises the running of other programs;
- maximises the use of the computer's memory;
- handles inputs and outputs and the storage of data;
- handles interrupts.

## Types of operating system

Type	Definition	Example of use
<b>Batch processing system</b>	<b>Data or programs are collected grouped and processed at a later stage</b>	Payroll , stock control and billing systems.
<b>Realtime systems</b>	<b>Inputs immediately affect the outputs timing is critical</b> i.e. they are capable of influencing the source of the data e.g. control where data from sensors is processed immediately and affect the outputs - controlling some device. <b>Timing is critical</b> and the term real-time control system	e.g. control of nuclear power plants.oil refining, chemical processing and air traffic control systems
<b>Realtime transaction -</b>	<b>Inputs immediately affect the outputs but timing is not critical</b> Each transaction is completed online as it arises e.g. booking systems -each booking is online and a database of bookings can be amended interactively and very quickly whilst another user is <b>locked out</b> so <b>cannot double book</b> or alter that record at the same time.	<b>Holiday and airline booking systems</b>  <b>Difference between realtime and realtime transaction.</b> In real time <i>time is critical</i> and delays can be catastrophic but in realtime transaction systems there is no time criticality. E.g. poor speeds in airline control would be dangerous but poor booking speeds would not be so crucial.
<b>Online processing</b>	<b>Processing performed under the direct control of the CPU</b> whilst the user remains in communication with the computer	
<b>Offline processing</b>	<b>Processing which is done away from CPU</b>	e.g. batching together of clock cards, filling in O M R forms.
<b>Single-user on-line</b>	<b>Provides for interaction between the job and the user,</b> which may influence the course of processing.	word processing

	Such systems may be single-user (e.g. a personal computer).	
<b>Multi-access on-line</b>	<b>Many users linked by workstations to a central computer such as in a network.</b>	Holiday or airline booking system One person must be locked out when another is updating the file. This helps to prevent Double booking
<b>Interactive processing</b>	<b>The user has to be present and program cannot proceed until there is some input from the user</b>	Select from a menu at ATM.
<b>Distributed system</b>	<b>Processing is carried out independently in more than one location, but with shared and controlled access to some common facilities.</b>	Databases e.g. libraries
<b>Multiprogramming :</b>	<b>Ability to run many programs apparently at the same time.</b>	Mainframe systems Each job is allocated a small amount of processing time ( <i>time slice</i> ) in turn.
<b>Multi tasking</b>	<b>The ability to hold several programs in Ram at one time but the user switches between them.</b>	Usually uses GUI's Facilitates import and export of data

## Databases and files

- A **database** is an **organised** collection of **related files** of data
- A **file** is an **organised** collection of **related records**
- A **record** is a collection of **related fields**
- A **field** is a collection of **related data**
- A **keyfield** may be used for uniquely identifying an individual record.
- **Fixed length field/** record each field of fixed length and each record a fixed number of fields

J	O	E				A	N	N	E					
---	---	---	--	--	--	---	---	---	---	--	--	--	--	--

*Adv* updating simpler + easy to find each field in record

*Disadv* wastes memory storage space

- **Variable length fields** is of different lengths with each field terminated by a marker and each record terminated by a marker each record can contain a different number of fields

J	O	E	*	A	N	N	E	*						
---	---	---	---	---	---	---	---	---	--	--	--	--	--	--

*Adv* saves storage space

*Disadv* difficulties of updating could lead to slower access speed if new or updated data won't fit in previous spaces pointer etc.

- **Serial File** - **unsorted** file usually a temporary file.
- **Sequential file** – a **sorted** in the order of the keyfield file need to search all records until find the one you want.
- **Random file** – gives **direct access** to individual records without without having to access other records first  
Uses \* when fast direct access to a record is required eg car registration / current orders / estate agents records details for one particular house
- **Database of a collection of related files of data**

### *Advantages of databases over single filing systems*

1. Minimises data duplication
2. Users access most up to date information
3. Increased security

**Data types and logical operators**

**String:      integer:      real :              currency:      dates:              boolean:**  
**calculated:      picture:              sound :              video**

Look at the file below and say what data type which each field is;

Membership No	
Name	
Address	
Date of Birth	
Cost of membership	
Height	
Yes/ No	
	

Membership No	Name	Gender	Club	Age group
234	J Smith	F	Netball	Under 11
612	R Jones	M	Football	Under 15
923	H Davies	F	Gymnastics	Under 11
164	K Evans	M	Fotball	Under 11

Which records satisfy the following criteria;

1. Gender = F **AND** Age group = Under 11 .....
2. Club = Football **OR** Club = Netball .....

**Creating Files**

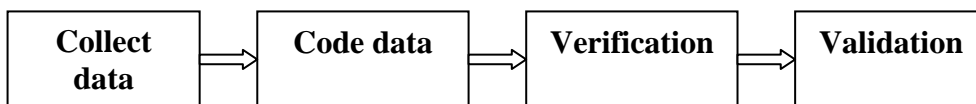

**Collect data /Data capture** Data is usually captured or collected by;

- \*questionnaires
- \*bar codes
- \*surveys manual or automatic eg traffic flows, opinion surveys
- \*official forms
- \*data logging

### **Coding and validating of data.**

- **it takes up less memory on disc**
- **it is easier to do searches on standardised data.**

### **Verification**

**‘Process of checking that data has been copied over correctly from one medium to another’**

*Errors that can occur*

<b>Transcription errors</b>	Typing in the wrong character by accident eg 2 instead of a 7
<b>Transposition Errors</b>	ie keying in in wrong order eg 56789 instead of 57689

These can only be checked by

- **double entry keying in and cross checking**
- **a careful visual check**

### **Coding data**

Eg houses can be coded as TR = terraced DT = detached SD = semi detached  
Gender M F

### **Validating data ‘Validation is the process of ensuring data is valid and legal’**

When creating fields in a file the user often puts controls over the way in which data is entered. This ensures that;

- \* data is entered into the correct format
- \* data is sensible
- \* reduces the risk of mistakes on data entry

## Payroll

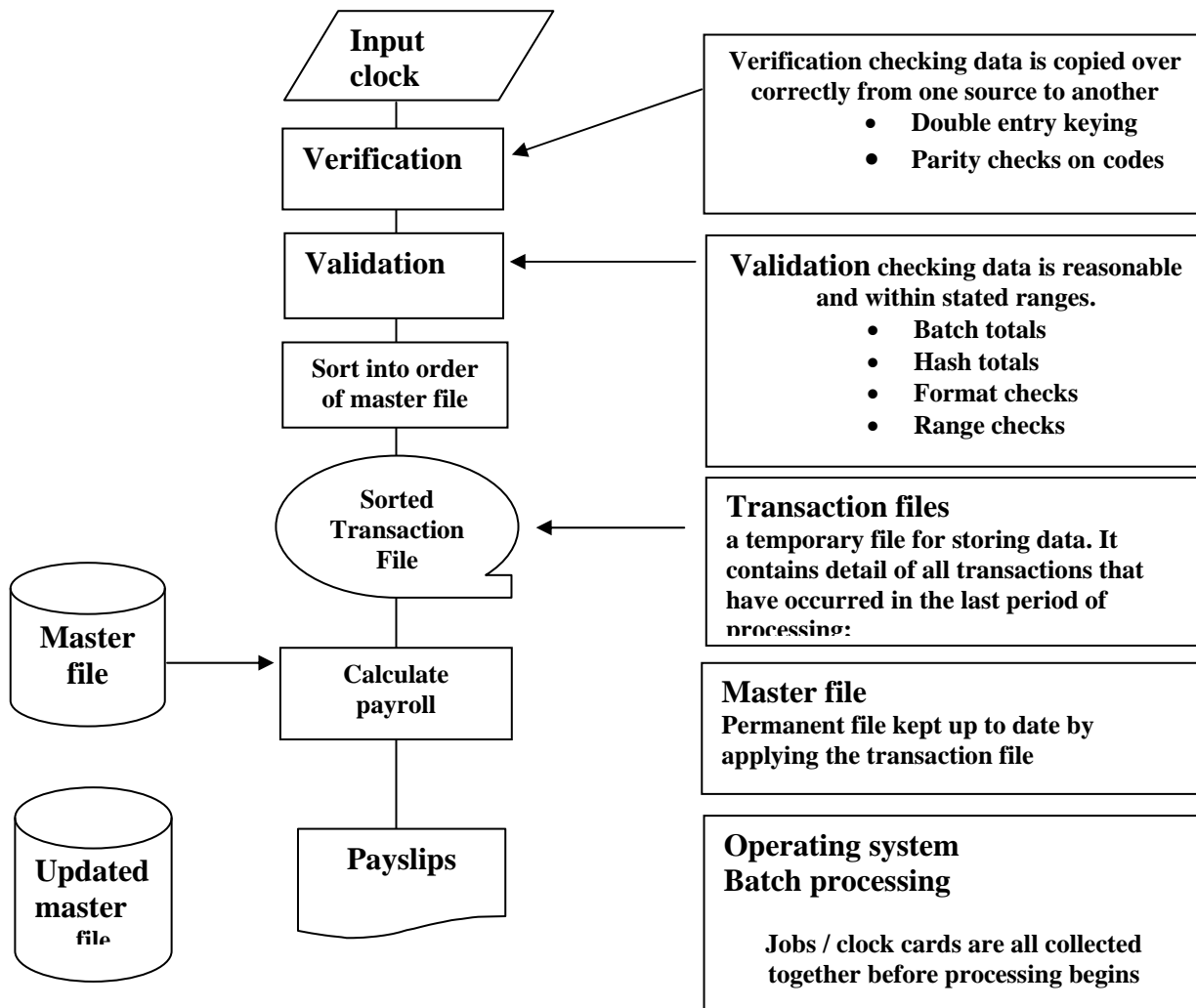

**N.B. archive file** *an archive file is kept for legal reasons and is stored off-site;*

### Types of data validation

- **Hash Totals**

Formed by adding together a series of records. During processing the computer will add up the field numbers and compare it with the stored total if they do not match then an error has occurred.

- **Batch Total**

This is like hash totals but uses the number of records in the processing run  
eg Payroll

**Transaction file**

	Employee No	Hours worked
1	101	40
2	102	35
3	103	42
<b>3</b>	<b>306</b>	

**Batch Total      Hash Total**

**Master file**

Employee No	Name	Address	Dept	Wage rate	Gross pay
101	J Smith	Llys Aber	Sales	£5.00	£2689
102			Stock	£4.50	£1789
103			Manager	£7.00	£3060

**Other validation techniques**

**Range Checks**

To ensure data items are in an acceptable and sensible range eg employee code between 1 – 200

**Format Controls** - set these up when creating files.eg enter number as 99.99 or date as 99/99/99

**Other types of validation**

**Check Digits**

Frequently used when reference numbers are needed eg **barcodes on supermarket products, ISBN number on library books**, customers reference numbers on billing system etc.

The account or reference number is weighted in the following way;

eg 2 3 1 7 6

$2 \times 5 = 10$

$3 \times 4 = 12$

$1 \times 3 = 3$

$7 \times 2 = 14$

$6 \times 1 = 6$

$10 + 12 + 3 + 14 + 6 = 45 \quad 45 / 11 = 4 \text{ remainder } 1$

The number becomes 2 3 1 7 6 1 Check digit.

The computer will do this calculation every time the number is scanned or entered and if there is a mismatch it will have to be rescanned or re-entered again.

**Backup procedures**

**Grandfather father son system for payroll**

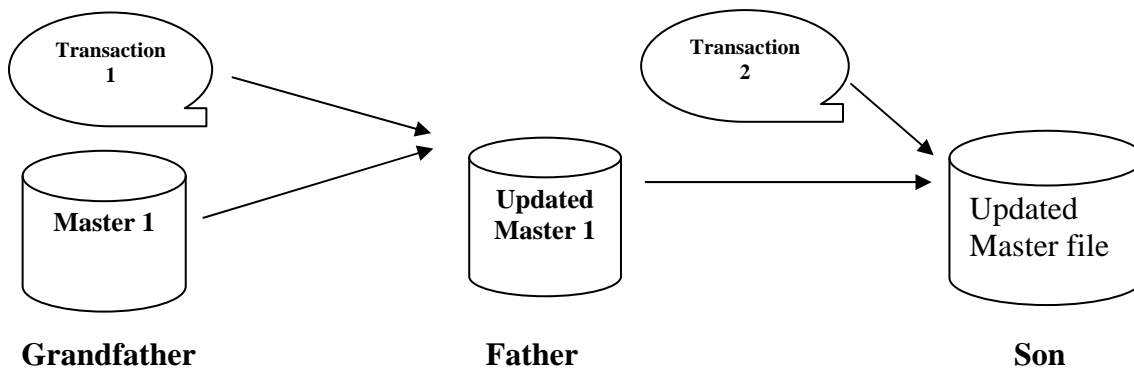

**1. Physical protection of the data.**

- keep BACKUP copies in a safe place
- use an online tape or disc streamer which automatically backs up data on a network
- put the write protect notch on your disc
- make hard discs read only
- keep copies in fireproof boxes or computer discs in fireproof rooms.
- use grandfather father son security system in batch processing systems  
e .g. payroll
- Lock computers to desks

## 2. Software protection of data

### A. Unauthorised Access/ hacking

- **Hierarchy of Passwords**
  - Identification User Name
  - Authentication Password
  - Authorisation What files you can see and what you are allowed to do  
Read only write only or read and write
- **Encryption** Coding data at one end sending it and decoding it at other end.
- **Voice / hand prints** To access rooms
- **Smart cards** To access rooms and computers

### B Spreading of viruses

- **Write protect** media so can't be written onto
- **Don't copy illegal software**
- Use a **virus scanning** software and **virus eradication** program. Make sure this is **kept up to date with the latest virus definitions** – available from the Internet.
- Don't download from the Internet straight onto hard disk
- **Control access to portable media** and do not let users use own disk etc on the organisations system.

### C. Computer fraud – white collar crime keep **transaction logs**

- **Bogus data entry** when entering data
- **Bogus output** -output may be destroyed to prevent discovery of fraudulent data entry or processing
- **Alteration of files** eg employee alters salary rate or hours worked
- **Blackmail** as a result of hacking into private files

## Computers and the Law

**The Computer Misuse Act 1990** makes it illegal to...

- gain unauthorised access to a computer's software or data (**hacking**) - including the illegal copying of programs.
- gain unauthorised access to a computer's data for **blackmail** purposes.
- gain unauthorised access to a computer's data with the intention of altering or deleting it. This includes planting **viruses**.
- copying programs illegally (**software piracy**)

A conviction may lead to a fine and a 5-year prison sentence.

## Copyright Laws

1. It is illegal to copy a program from one floppy disc to another without the permission of the legal copyright owner
1. It is illegal to copy one program into more than one computer without a licensing agreement.

### *Types of copyright crime*

**Illegal copying : -software piracy**

**Purchasing one legal copy and loading it into several computers memory  
Transmitting software over telecommunications thus creating a copy.**

**Software piracy** is the unlawful copying, distribution and use of software. each copy of software that is purchased is licensed for use on one machine.

## Data Protection Act 1998

There are many organisations which hold **personal** information about individuals.

**Examples :**

- **Tax Office**
- **Doctor / Dentist**
- **National Insurance**
- **DVLC**
- **Police**

**Reasons for the introduction of the DPA**

**People were worried that;**

- data held about them was wrong
- about hacking into personal data
- they were being asked for data which was irrelevant to the purpose they gave it e.g. What is your religion ?
- the length of time data was held on computer about them
- data given for on purpose e.g. medical data was being sold on to companies who produce mailing lists for junk mail.

**Data subjects' rights** under the Data Protection 1998 Act have been extended. Data subjects rights include obtaining copies of their credit rating records and having any errors corrected or removed. Read about rights related to credit records, credit reference agencies and black listing.

The new Act also includes any manual data that is structured. This basically means that any personal record can be retrieved using an index or similar means. Certain manual records are granted some exemptions from the new Act until 2007 to give controllers adequate time to prepare their systems.

**Some of the most important Data Protection Principles.**

<p><b>1. Personal data shall be accurate and where necessary, kept up to date.</b></p> <p>They can ask to see it and have it altered They could sue if the inaccuracies caused them harm</p>	<p>The data controller must ensure that data is backup up regularly, virus checked, and restricted to named authorised persons by means of passwords or other means.</p>
<p><b>2. Personal data obtained only for one purposes must not used for another</b></p>	<p>The Data Controller may use to <b>specify the purposes</b> for which personal data are obtained:</p>
<p><b>3. The data must be relevant to the purpose for which it is given</b></p> <p>They can prevent selling one.e.g. for personalised junk mail</p>	<p>.A dating agency may collect and process data for the purpose of matching compatible people. They cannot then use that data to identify prospective punters for a sideline in cosmetic surgery</p>
<p><b>4. Personal data shall not be kept for longer than is necessary</b></p>	<p>Data may be collected from applicants for a job. That data can only be stored for the period of assessment, interview and selection. After that it should be discarded.</p>
<p><b>5. Gather the data fairly and lawfully</b></p>	<p>They must register the use of the data with the Commissioner</p>
<p><b>6. Personal data shall not be transferred to a country or territory outside the</b></p>	<p>There are certain circumstances where the Eighth Principle</p>

<b>European Economic Area, unless that country or territory ensures an adequate level of protection for the rights and freedoms of data subjects in relation to the processing of personal data.</b>	does <b>not</b> apply to a transfer of data. They are: the data subject has given consent to the transfer the transfer is <b>necessary</b> for reasons of substantial public interest. The Secretary of State can order and explain such a transfer.
--	---

### **Exemptions on data**

1. Personal data which must be exempt to safeguard national security eg armed forces
2. Personal data required by law e.g. inland revenue
2. Personal data kept by the user on himself or family or household affairs for own or recreational use. e.g. home accounts.

### **Exemptions from a subjects right of access**

1. Data relating to a police investigation , criminal records or collection of taxes.
2. Data between a solicitor and his client 'legal professional privilege'
3. Data held solely for statistical purposes.

### **Exemptions from disclosures**

1. Disclosures needed to prevent urgent risk of injury or health eg hijackings
2. Disclosures required by law e.g. Inland Revenue.

## **Networks**

**“A set of computers LINKED together”**

**LAN :**        **Local area network** - a smaller network contained within a room or building e.g. a school network.

**WAN :** Wide area network – ‘**a network of networks**’ ;bigger networks covering cities or linking various external network via gateways. e.g The Internet or a large multi-national company

### **Client server network**

There is one central fileserver which stores files and/or programs to be access by other terminals.

### **Peer to peer network**

All stations in the network have equal status. Are often a form of distributive processing sharing the processing between intelligent terminals. Applications may be stored on different computers and accessed by all..

**Advantages of networks over standalone systems**

- Share programs
- Share data files
- Share peripherals e.g. printers and scanners
- Electronic mail

**Disadvantages**

- If files server goes down the network could crash.

Crimes on networks	Prevention
<b>Hacking – unauthorised access</b>	<b>Hierarchy of passwords:-</b> ID authentication authorisation <b>Encryption:-</b> - code one end --- send in scrambled form—decode at other end - both ends must have codes. <b>Smart cards – programmable cards</b>
<b>Spreading viruses</b>	Virus eradication and detection programs Don't download from the Internet onto hard disc Don't bring in floppy discs from outside.
<b>White collar computer fraud</b>	Transaction logs

**NETWORK TOPOLOGIES:-** “how we arrange our network”

**BUS or ETHERNET network**

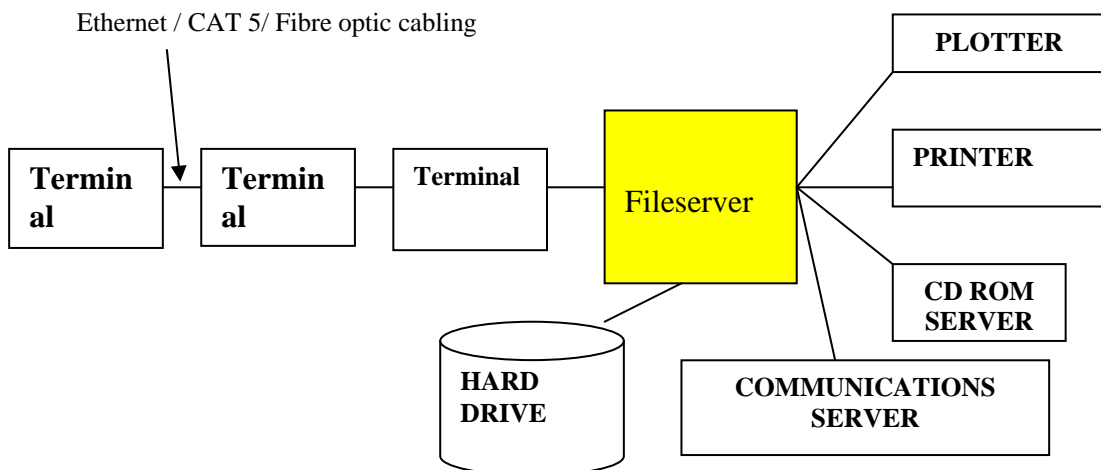

Workstations are connected to the main fileserver by cable and data can travel in both directions to reach the various nodes in the network.

**Advantages of BUS topology** The BUS topology makes the addition of new devices straight forward by attaching them to either end. Terminators are at either end of the network

### RING network

The Cambridge ring has **no host computer** and none of the nodes need to have overall control of access to the network. Messages in the ring flow in one direction from node to node. Messages addressed from one node to another are passed around the ring until the receiving node is ready to receive it.

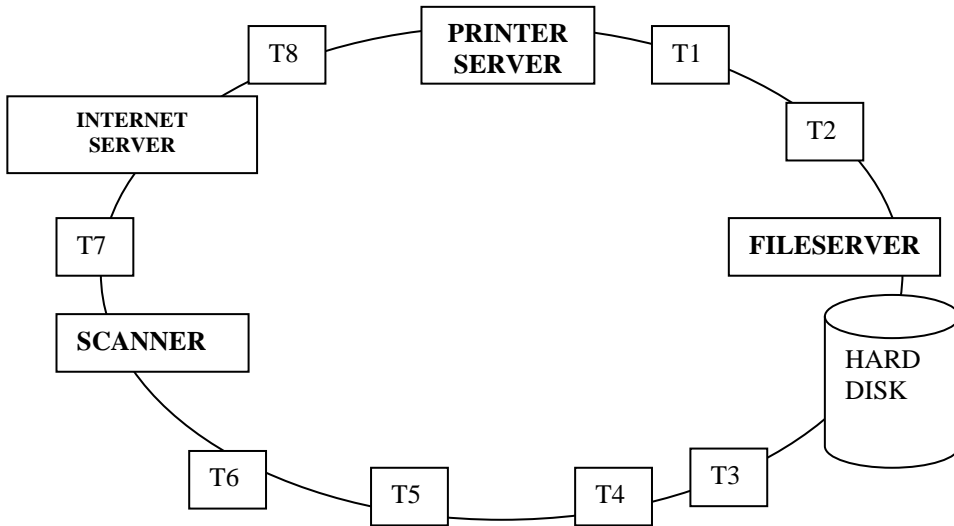

#### Advantages of a Ring network

- There is no dependence upon a central host as data transmission is supported by all devices on the ring.
- Very high transmission speeds are possible.

### STAR network

Each node is connected to to a CPU at the centre. Popular topology for a **WAN**. Messages pass through host which interconnects different devices on the network. The central host **switches** messages point to point.

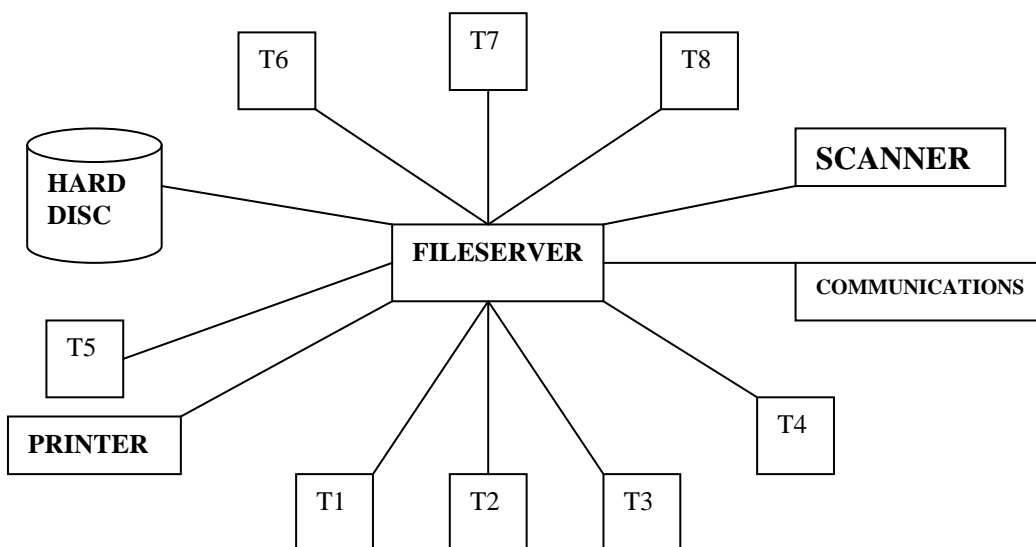

#### Advantages of a Star network

- Suitable for WAN's where large organisations rely on a central computer for the bulk of data processing tasks
- Central control of message switching allow a high degree of security
- Each spoke is dependent upon the rest and the central CPU can identify any faults

- Data transmission speeds can vary from spoke to spoke so one can use a high-speed device and another a low speed e.g. disc drive.

***Disadvantages***

- Network is vulnerable to central hub failures.  
As a distributed system, some processing is still possible at the nodes but internode connection is lost.

**Ways of transmitting data**

Cable	Networks; Internet; Digital TV
Microwave	Internet
Infra red	Mouse; keyboard
Radio	Mobile phones
Satellite	Digital pictures; Digital TV

## Systems Analysis and Design

### Analysis Systems design Implementation Maintenance

### Analysis

Analysis of existing data and data processing involved in the system

#### *Understanding the current system*

##### *(1) Fact finding technique*

- \* **Interviewing** different levels of questions to different people
- \* **Questionnaires** especially if over a wide area. questionnaires to users and to managers.
- \* **Observation and videos** valuable info. can be collected working conditions and practises, inefficiencies identified and bottlenecks. However the problem with observation is that people often think they are being spied upon and work differently when being watched.
- \* **Reading existing documentation manuals**, job descriptions training aids and guides, looking at existing files standard letters

### Feasibility study

This involves investigating the options and producing a feasibility report it would contain the **costs and benefits** of the new system

Costs	Benefits
Job losses / cost of redundancies	Saving in staff salaries
Cost of retraining	Offer more services
Cost of hardware and software <i>Choosing software</i> *write own in house programs *Use a software house and * buy off the shelf	More up to date and efficient service.
Costs of new rooms	More sales revenue because of improvements increased productivity
Running costs	

## System design

- Hardware
- Software
- Design of user interface
- Defining file structures
- Data validation techniques
- Designing input forms
- Report layouts
- Manual procedures eg collecting data for input and delivering output to people.
- Which operating system - batch, multiuser etc,
- Security:- Passwords / Backup procedures /Data encryption etc
- Environmental and health hazards consideration.

## Implementation

### User participation and training

Users should be involved from the start and given in house on the job training or send on courses. *The management has to negotiate with trade unions at an early stage to ensure a smooth changeover otherwise user resistance could cause the new system to fail* They must feel that the computer system meets their needs, and have confidence to operate it. The ergonomics of the computer facilities are increasingly being considered by systems analysts

### Changeover strategies

#### ***DIRECT***

Old system dropped and new system introduced without delay.

**Adv:** fast to implement and minimum duplication of data and effort

**Disadv:** If error in new system then it could fail

Suitable for **realtime systems** eg booking systems control or POS systems

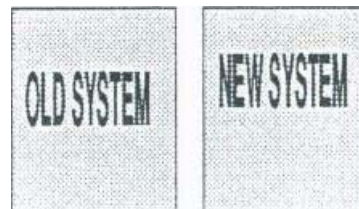

### Parallel running

New system runs along side of old system

**Adv:** If error in new system then data or transactions are recorded so errors in new system can be corrected without data loss.

**Disadv:** Duplication doubles work for staff  
Suitable for **batch processing** systems / stock control or office systems

Users will drop old manual system when new system is error free and they have confidence in it.

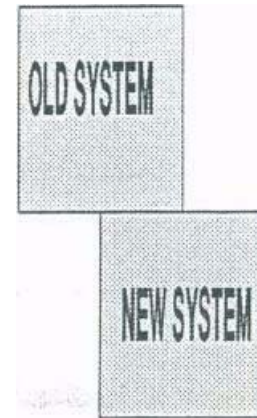

:

NB **Pilot and phased** changeover could be applied to either direct or parallel running

**PILOT** operation only a part of the organisation has new system to investigate faults and correct them before going full scale eg accounts dept only

**PHASED** changeover

Only some files eg some customer accounts are computerised to check the system

## **Testing**

Programs are tested individually and then linked together until whole system interaction is tested. A full range of test data is used to check data validation techniques ie normal data incorrect data extremes data and highly unlikely data which may still be correct, maximum and minimum values empty and full files in fact every possible occurrence they can think off. Modifications may be needed these will be carried out and then the system retested.

## **Maintenance**

When the system is in full operation it must be reviewed at regular intervals in order to monitor performance  
Documentation kept up to date so future programmers can develop, improve and correct the system.

It may need to expand in some areas contract in others or add new developments eg if the government introduces a new tax.

Errors corrected eg wrong headings etc. which might c

### ***User documentation***

- How to use the system
- Details of disks or tapes required
- Operating system memory required.
- How to load save print and simple procedures
- Backup procedures to be used
- Guarantee

### **Technical documentation**

Technical staff need to know how to run the system load disks what to do in the event of a breakdown or errors or for expansion of use.

- File and data structures
- Current version
- Listings of programs

## **Evaluating the system**

- \* Observation of outcomes do they work does the system do what it is supposed to?
- \* Staff ease of adoption of new system
- \* Customer satisfaction with new system
- \* Keep a log of - hardware breakdowns ;software errors; process inefficiencies both manual and computerised.

### **Why a system might be unsatisfactory when installed**

- \* Costs exceed possible benefits
- \* System could be technically good but beyond the skills of the users to operate.
- \* System may crash when unexpected input is received eg an empty file.

### **Data logging.**

**Data logging** is the automatic recording of data as it is produced.

### **Features of a data logging system**

- A process is monitored by **sensors**.
- The computer controlling the system samples the readings at **regular accurate pre set time intervals**
- The readings are **recorded**, usually by storing them on backing store of disc or tape and also printed out as hard copy.
- The data is **analysed** e.g Average temperature. Max and Min temp, Hours of sunshine
- Results may be displayed continuously in **graphical or table** format:

### **Advantages of using a computer to log / collect data**

- 24 hour monitoring
- No human presence needed
- Accurate reading
- Accurate recording

### **Disadvantages**

- Over reliance
- Program errors could cause problems
- Cost of system
- Loss of jobs



**Automatic control of a greenhouse.**

*The situation* - A large nursery has a number of greenhouses which need constant attention. To save workers having to continually check them, an automatic computer-controlled system is introduced. Each greenhouse needs to be kept at constant temperature and constant humidity. These can be controlled by:

- opening or closing overhead ventilators - opening the ventilators decreases the temperature and humidity, while closing the ventilators increases them;
- switching a fan on or off - on decreases temperature;
- switching a heater on or off - on increases temperature;
- putting misters on or off - on increases humidity.

*Data Capture* - The greenhouse has suitably placed sensors to measure -

- temperature;
- humidity.

The temperature sensor is digital but the humidity sensor is analogue.

Role of the computer - The computer receives readings from the sensors. Readings from the humidity sensor are passed through an analogue-to-digital converter. It is programmed to check humidity and temperature at 10-second intervals and take appropriate actions eg.

- if temperature is too low then switch heater on; shut the ventilators slowly, checking humidity and temperature; switch the fan off if necessary;
- if humidity is too low, then put the misters on until humidity recovers.

***A school collects data from its computerised weather station***

a) Name **three** sensors that could be used on the computerised weather station.

.....

b) Give **two** methods of *permanently storing* the weather data collected.

.....

c) Give **two** methods of *presenting* the weather data collected.

.....

d) Give **two** statistical methods of *analysing* the weather data collected.

.....

.....

e) Give **two** advantages of using the computerised weather station to collect data rather than using traditional methods of collecting weather data.

**Advantage 1**

.....

.....

**Advantage 2**

.....

.....

The Meteorological Office has computers which uses computer simulations to help forecast the weather.

a) What is a computer simulation ?

.....

.....

b) Give **two** advantages of using simulation techniques to forecast the weather?

**Advantage 1**

.....

.....

**Advantage 2**

.....

### Computer Control

**Analogue sensors** measure variations

E.g. Air pressure, temperature, wind speed, moisture sensors etc.

**Digital sensors** measure on off states *i.e. circuit complete circuit broken*

E.g. Pressure pads, magnetic, switches. tilt sensors

Program controls how the computer system responds to the data from sensors.

E.g. a simplified diagram of a washing machines program might be as follows;

Water on	Spin	Motor	Pump	Heater	Event
0	1	1	1	0	Spin cycle pumping water out
1	0	1	0	1	Fill up and heat water

Some control systems have **FEEDBACK**

**i.e. a program responds to data from sensors and control output device which affects the data coming in from sensors**

E.g. central heating system in the home.

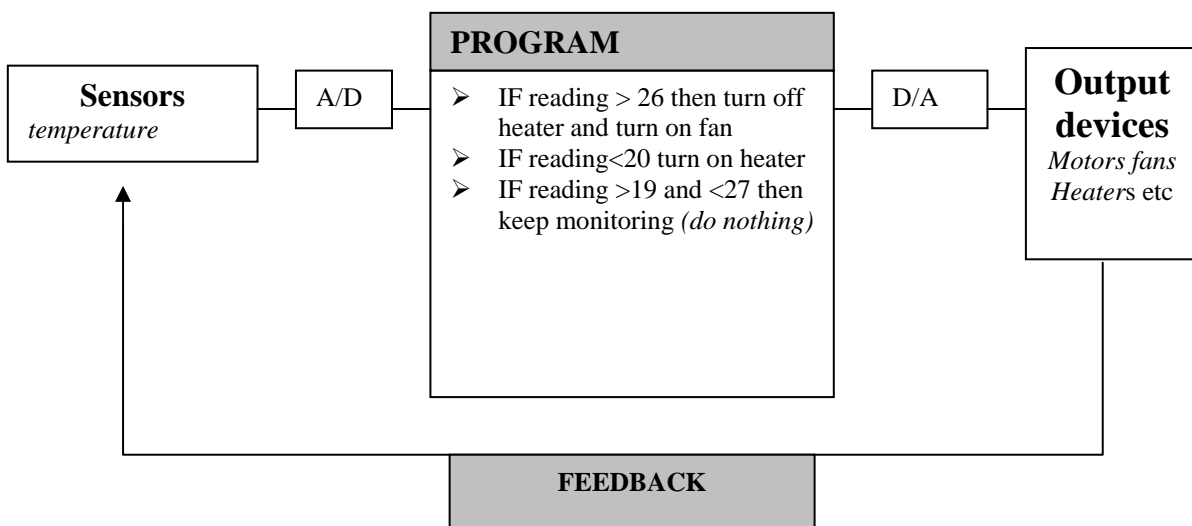

**Process control** means automatic control of an industrial process.

A computer is used to control an operation by monitoring readings from **sensors** and sending **control signals** when necessary.

#### **Characteristics of process control -**

- It is a **real-time** operation - input from sensors is processed and control signals are sent back almost immediately.
- It is an example of the use of **feedback** - the sensor input is used to adjust the process if it is out of balance.
- The computer usually controls the supply of materials and the timing of each part of the process.
- Some more sophisticated systems allow for 'learning' to take place. The computer 'remembers' how the best results were obtained and attempts to reproduce those results.

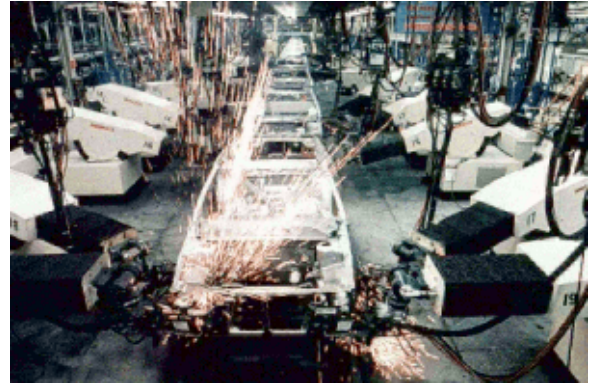

#### **Requirements for process control**

In a computerised process control application the following items are generally required -

- **a controller** - usually a dedicated computer or a microprocessor-based circuit;
- **sensors** to provide information on the process under control. If a sensor is analogue an analogue-to-digital converter is needed;
- **actuators** to carry out control actions in response to signals from the processor. If the actuator is analogue, a digital-to-analogue converter is required;
- **display devices** (eg monitor screens, LED or LCD displays) so that a human operator can check the system;
- **a printer** to provide hard copy when required.

**Library systems**

The library stores a database of all its books and all its members. Searches may be undertaken to find if a book is available, or to list all the books for a given author etc...

**All books are labelled with a unique barcode**, and every member of the library has a **membership card with a barcode printed on it**.

When a member borrows a book, the barcode of the book and the membership card are both swiped and recorded, together with the date on a **transaction file**.

When the book is returned, that transaction is marked as completed and archived.

The computer can produce reports about the most popular authors etc. **Network** links may be made to other libraries in the area.

**Searches** can be made by Author or Title or Publisher

# Files

Student No	Name	Address	Tel	Course code
45668	J Smith	The Willows	427835	27

**Administration details**

Accession No	ISBN	Title	Author	Category
9678	23465432	Great Expectations	Charles Dickens	Fiction

**Catalogue details**

Student No	Status
45668	6 books

**Borrower status**

Accession No	Student No	Date out	Date back	Fines
5634	23484	12/11/02	19/11/02	£0.0

**Loans details**

Accession No	Student No	Date out	Date back	Reserved by
5634	23484	12/11/02	19/11/02	78698

**Reservations details**

# Processes

- Search by**
  - Title
  - Author
  - Publisher
  - ISBN
  - Accession No
- Overdue letters**
- Reservations**
- Request books from other libraries**
- Update records**
- Sort records**
- Yearly stocktake**

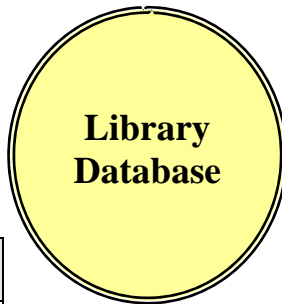

## The Borrowing process

